

**INSTALLATION INSTRUCTIONS**  
**FOR**  
**AIR CONDITIONING CAT D8R**



HAMMOND AIR CONDITIONING LTD  
INGERSOLL, ONT, CANADA  
1-800-267-2665 Phone  
1-888-267-3745 Fax

EVAPORATOR COIL: The evaporator coil mounts in front of the heater coil directly ahead of the cab windshield.

1. To access, remove the filter intake cover and the air filter coil and A/C hose knockouts. Loosen the two bolts that hold the heater coil in.
2. Insert the evaporator core into the area in front of the heater coil. Line the slots on the mounting flanges on the evaporator coil up with the two bolts that held the heater coil in place.
3. Tighten down the heater bolts to clamp the evaporator into position.
4. Seal any air gaps around the top or sides of the coil.
5. Leave covers off until the thermostat has been installed and the system has been tested for leaks.

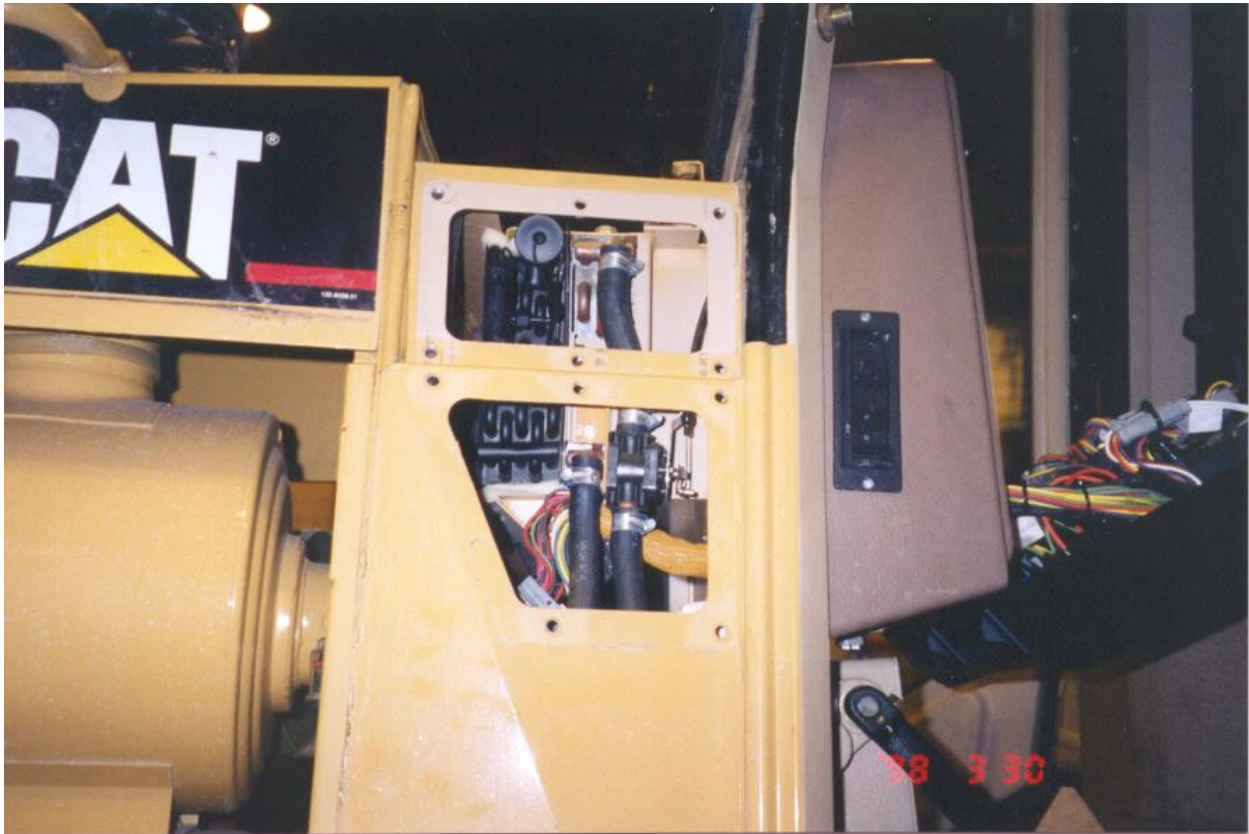

Evaporator in place alongside heater coil.



Top of evaporator assembly in heater box.



Evaporator assembly showing hoses.



Evaporator cover in place with thermostat.

THERMOSTAT: The thermostat mounts in the factory position on the front dashboard.

1. Open the control panel in front of the operator's position to access the wiring and set-up locations for the thermostat.
2. Locate the factory position for the thermostat (see photograph) and cut out the covering over the mounting hole. Make sure the thermostat has the backing nut in place before installing. Insert the thermostat into the hole. Tighten down the securing nut and install "Temp" knob.
3. Run thermostat probe out of the cab (through the factory knockout) into the evaporator coil area. Insert the probe into the evaporator coil about 6".



Thermostat location (one possible position)



Thermostat location (possible - depends upon instrument locations)

Another option for the thermostat is to use a pre-set style. This will allow the thermostat to be hidden behind the instrument panel but will not allow the operator to adjust for personal comfort.

**Please advise thermostat style when ordering system.**

RECEIVER DRYER: The receiver drier is mounted at the back of engine compartment against the side wall on the right side.

1. Mount the dryer bracket on an existing bolt and hardware. The drier bracket is designed to use up to a 10mm bolt for mounting
2. Secure the dryer to the mount using the large gear clamps provided. Ensure that the inlet side of the dryer points towards the front of the tractor.



Drier location on side of rear engine compartment.

COMPRESSOR: The compressor mounts on the right side of the engine on the mount point above the alternator.

1. Bolt the compressor mount onto the two open bolt holes with the long (5") bolts provided in the kit.
2. Place the compressor on the mount tightener ears as shown in the pictures and fasten with the hardware provided.
3. Route the belt around the compressor and crankshaft pulley. Tighten using the adjuster ears built into the compressor mount.

**\*\*NOTE\*\*** Ensure the oil fill port on the compressor is oriented 'UP'

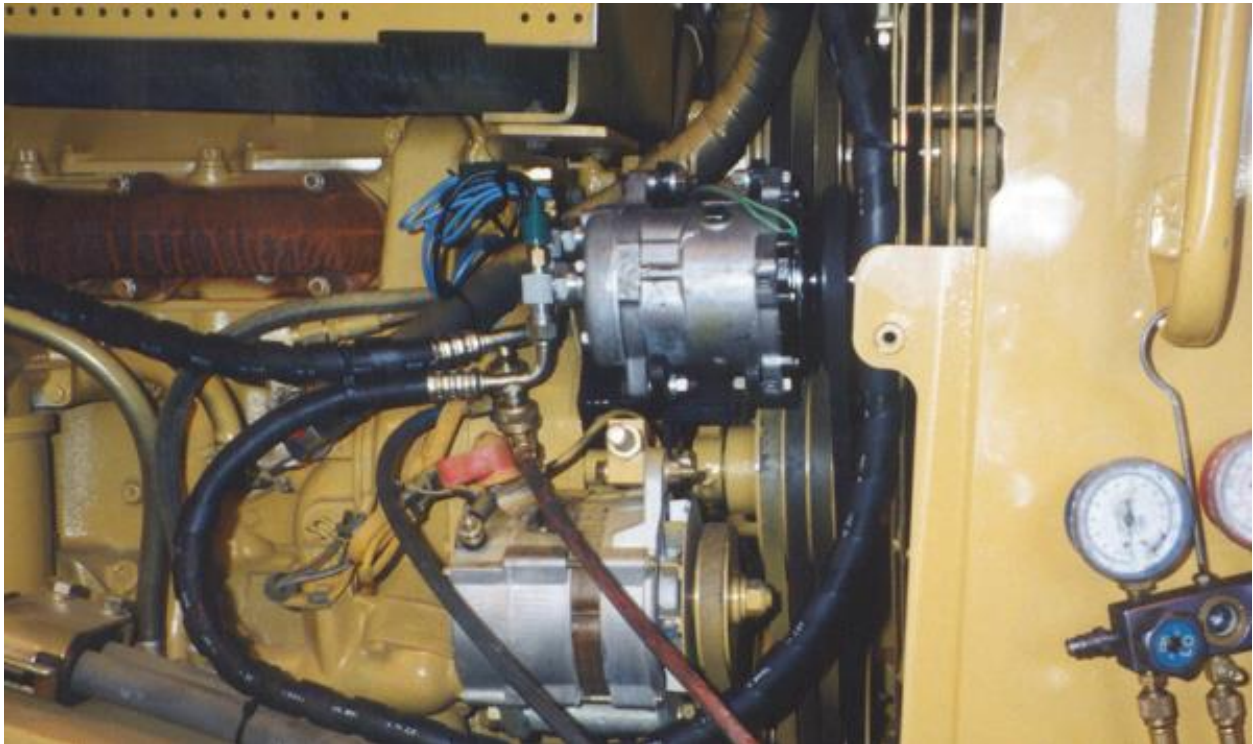

Compressor mount and drive in place with hoses.



CONDENSER COIL: The 16" x 24" 3 row condenser is mounted to the fan screen across the top.

1. Hold the condenser in the desired location with the fittings towards the right side of the engine and the larger fitting (13/32") on top.
2. The top right and top left of the coil have specific mounting brackets for the assembly. The top right bracket picks up an existing bolt on the radiator shroud at the top and the top left bracket picks up the open bolt on the bracket mounting the hydraulic oil cooler.
3. Align the two hold down bars to be parallel with the screen and push the bars through. The spacing on some screens may need to be slightly adjusted (using a large flat head screwdriver) to accommodate the hold down bars. Turn the bars 90o to the screening and tighten in place. Make sure that the condenser is relatively level and clears the fan axle and any other obstructions. Lock the bars in place with the second set of fastening hardware with the large diameter flatwashers.



Left side of condenser assembly.

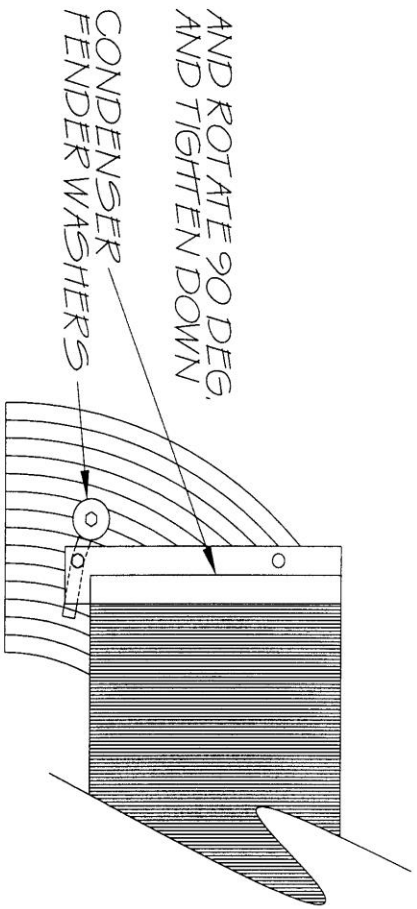
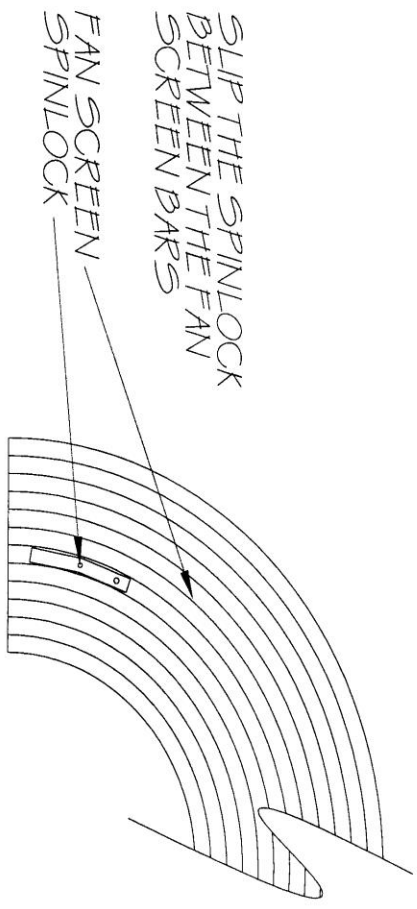

DRAWING TITLE:  
**SPINLOCK INFO.**

DRAWN BY:	J.S.
APPROVED BY:	J.L.
MODIFIED ON:	MAR. 15, 2002
REV.:	0
UNITS:	S.A.E.



Right side of condenser with hoses in place.

ELECTRICAL: The wiring set-up used in this system is designed to be very straightforward to install and understand.

1. The thermostat is mounted in, or behind, the panel as described above and draws power from the blower switch. The blower switch will have one position that is live when the switch is in any of the 'Air Conditioning' blower positions.
2. Connect the live A/C post on the blower switch to the thermostat by connecting the short 14ga red wire to the live blower post and then to the thermostat.
3. Run the black 14ga clutch wire (with loom) out into the heater box along with the thermostat probe. The probe is inserted into the coil through the hole in the cover plate and at least 6" into the coil.
4. The clutch wire runs out of the heater box with the suction hose and runs up to the compressor where the pressure switches are located.
5. Connect in series through the switches (order is not important) and connect to the compressor lead.

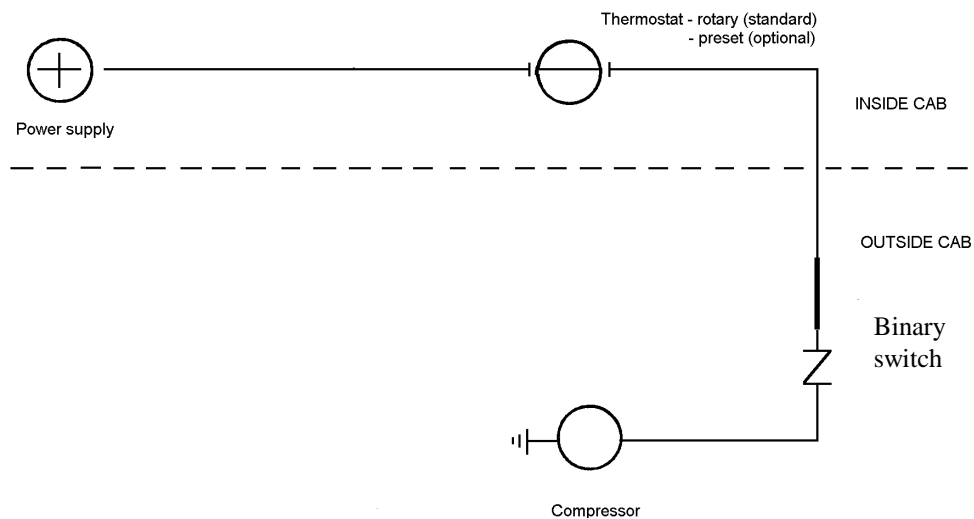

HOSE RUNS: All the hose fittings have been pre-assembled and tested for leaks.

5/16" hose condenser to drier:

Connect the straight fitting to the lower fitting on the condenser and route up and around as shown in the condenser pictures. The hose follows down the side of the fan screen and along the side of the engine to the 'INLET' fitting on the drier. Hook the 90o fitting on this end of the hose to the fitting on the drier.

5/16" hose drier to expansion valve:

Connect the 90o fitting on the hose to the 'OUTLET' fitting on the drier. Route the hose up around the back of the engine to the evaporator inlet cap plug. The cap plug will have to be slit as shown below to get the hoses through. If the cap plug is no longer present seal the hole with tar tape. Connect the straight fitting up to the expansion valve.

13/32" hose compressor to condenser:

Connect the 90o fitting with the 134a charging port up to the rotolock fitting on the discharge side of the compressor. Route the hose down to the frame and then up along the side of the engine screen. Tie to the fan screen with the 5/16" hose and connect to the top fitting on the condenser as shown in the condenser pictures.

1/2" hose compressor to evaporator:

Connect the 90o fitting with the 134a charging port up to the rotolock fitting on the suction side of the compressor. Route the hose down to the frame (with the 13/32" hose) and back along with the 5/16" hose to the evaporator assembly. Route the hose through the cap and connect to the outlet side of the evaporator.



Hoses into evaporator box.

**IMPORTANT:** Make sure "O" rings are used on all fittings. Use refrigeration oil on all "O" rings to achieve a proper seal.

## **CHARGING AND TESTING**

- 1) Pressure test the system using nitrogen to a pressure of 250 psi. Check for leaks.
- 2) Add 2oz of SP20 Sanden PAG oil to the system.
- 3) Vacuum the system for at least ½ hour.
- 4) Check that the vacuum holds.
- 5) Fill the system with 2.75 to 3 lbs of R134a refrigerant. DO NOT USE ANY OTHER TYPE OF REFRIGERANT OR IT WILL VOID THE WARRANTY.
- 6) Test the system. Check the cycling temperature of the thermostat. Adjust the thermostat settings if required to avoid coil freeze up problems. See the thermostat setting procedures at the end of these instructions.

# Refrigerant Flow Pattern in a Standard Air Conditioning System

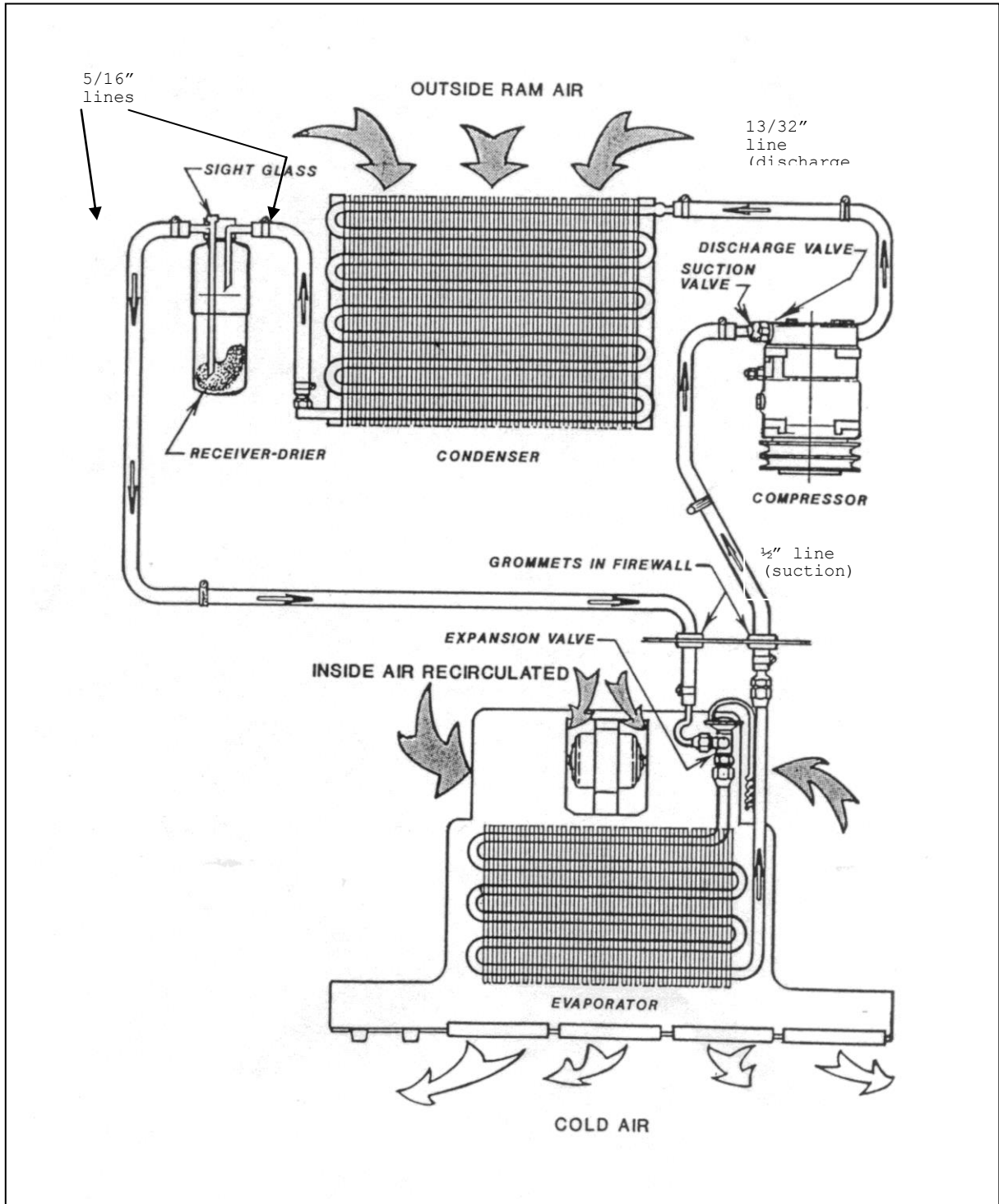



## Thermostat Setting Procedures

- 1) Thermostat types
  - a) preset
  - b) adjustable
    - a) A preset thermostat is adjusted to its specific cut in and cut out temperatures when manufactured and does not have a rotary adjustment for the operator.
    - b) An adjustable or rotary thermostat has been manufactured to a predetermined cut in and cut out temperatures, but it is also operator adjustable to achieve the desired comfort level.

Both types of thermostats can have their factory settings adjusted by turning the setting screws on the body of the thermostat. One body type has the setting screws mounted externally and labeled for direction of rotation. The other body type requires the removal of the plastic end plate to expose the set screw.

- 2) Thermostat probe location: The location of the thermostat probe in an evaporator coil can be very important to achieve the maximum cooling potential of the coil while also preventing coil freeze-up. There is no set location for the thermostat probe to be put that will be optimum for all systems, but several rules of thumb may be followed:
  - a) Insert the probe in the coldest area of the evaporator coil.
  - b) Insert the probe from the top of the coil down, if possible.
  - c) Make sure that at least the last 3" of the thermostat probe are in the coil.

To find the most likely area where the coil is the coldest, consider these factors:

- 1) Direction of air flow through the coil.
  - 2) The coil area likely to have the lowest air flow.
  - 3) The inlet locations of the refrigerant into the coil.
  - 4) The inlet of the hotter outside air into the coil area.
- 
- 1) Usually the coldest side of the evaporator coil will be the air outlet side. Often the thermostat probe can be inserted between the last and second last row of tubes.
  - 2) The lower air flow area of the evaporator coil in most systems tends to be near either end of the coil. These areas will be colder
  - 3) The area of the coil that the refrigerant inlet tube(s) occupy should be the coldest part of the coil.

4) If the system is equipped with an outside air intake, where and how that air is brought into the evaporator area can have a large effect on the coil temperature. If all the outside air is piped into the evaporator in one area, that area will be considerably warmer in hot weather.

By looking at all these different factors, the area of an evaporator coil most likely to be the coldest can be determined.

Once the probe is inserted, the A/C system needs to be tested. Run the system to ensure that the thermostat is cycling the compressor off at the appropriate temperature. A core temperature ranging between 25° and 30° F should cause the thermostat to cycle off. The air temperature at the vent outlet closest to the evaporator coil should be between 38° F and 45° F when the compressor cycles off.

If the thermostat doesn't cycle off after a reasonable cool down period, and the air outlet temperature has dropped below 40° F, the cut in and cut out settings should be adjusted until the compressor is cycling on and off regularly. Let the system run for a decent time period (at least 15 min) and then check the evaporator coil for any signs of freezing.

## Aeroquip E-Z Clip Assembly Instructions

Step 1. Cut the hose to proper length with an appropriate cutting tool. Aeroquip's hand held hose cutter has been specially designed for cutting all non-wire reinforced hose, such as GH-134 Multi-Refrigerant hose. Be sure the cut is made square to the hose length.

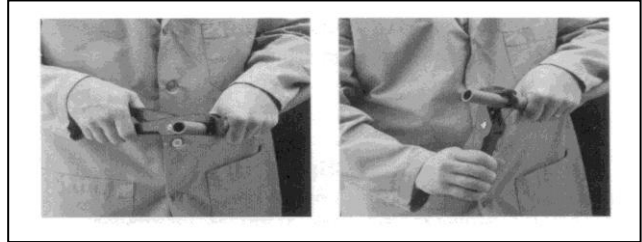

Step 2. Install two proper-sized clips onto the cut end of the hose. Orientation of the clips does not affect the performance of the connection. However, for ease of assembly, both clips should have the same orientation. NOTE: Failure to slide the clips over the hose at this time will require the clips to be stretched over the hose or fitting later. This may permanently damage the clip.

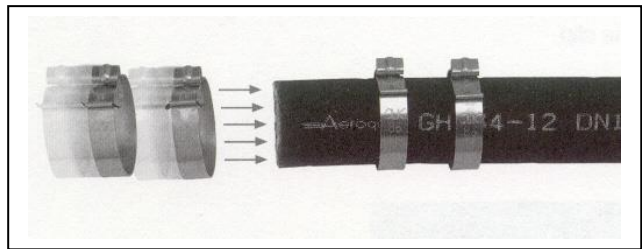

Step 3. Lubricate the nipple with a generous amount of the refrigeration or A/C system's compressor lubricating oil. This MUST be done to lower the force of nipple insertion.

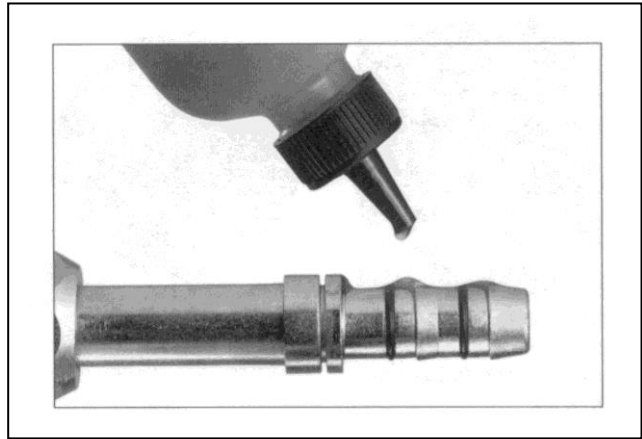

Step 4. Insert the nipple into the hose. To ensure that the nipple is fully inserted, check the gap between the cut end of the hose and the shoulder on the nipple. Care should be taken to avoid kinking or other damage to the hose during nipple insertion.

NOTE: Be sure to wipe excess oil from the nipple and hose.



Step 5. Snap the cage into the groove on the nipple. The arms should extend over the hose length. When the cage has been correctly installed in the cage groove, the cage will be able to rotate in the groove. This step **MUST** be performed to ensure:

1. The clips will be located over the O-rings on the nipple.
2. The connection will be compatible with the connection's pressure rating.

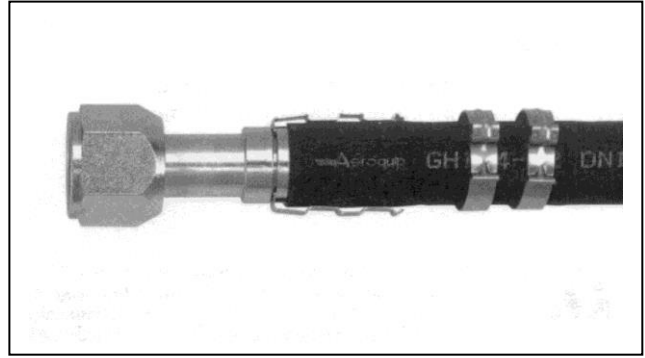

Step 6. Slide the clips over the cage arms and into the channels on each arm.

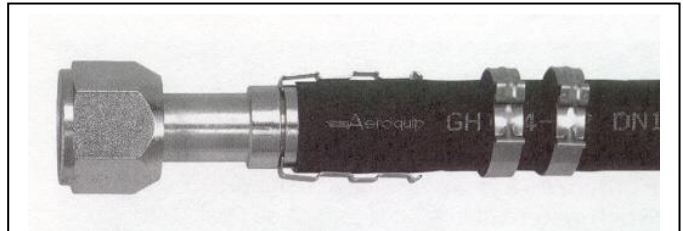

Step 7. Use the pliers to close the clips. The pliers should be positioned squarely on the clip connection points and should remain square during the closing of the clip.

**NOTICE:** E-Z Clip components should not be reused.

